

# Technical data sheet

Product features



## Cooking range drop-in gas 2x burner

<b>Model</b>	<b>SAP Code</b>	00007444
--------------	-----------------	----------

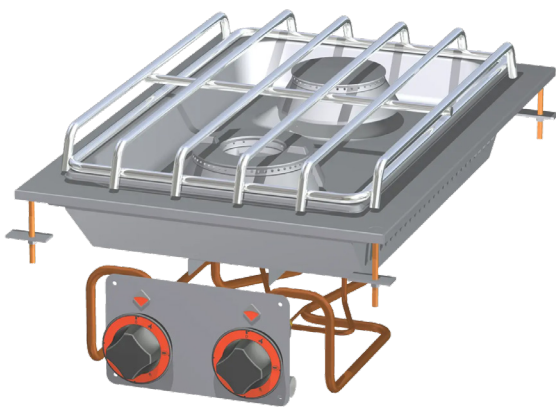

- Device type: Gas unit
- Power consumption of the zone 1 [kW]: 7,5
- Power consumption of the zone 2 [kW]: 5,5
- Ignition: Eternal flame
- Protection of controls: IPX5
- Material: Stainless steel

<b>SAP Code</b>	00007444	<b>Power gas [kW]</b>	13.000
<b>Net Width [mm]</b>	400	<b>Type of gas</b>	Natural gas, propane butane
<b>Net Depth [mm]</b>	600	<b>Number of zones</b>	2
<b>Net Height [mm]</b>	110	<b>Power consumption of the zone 1 [kW]</b>	7,5
<b>Net Weight [kg]</b>	16.00	<b>Power consumption of the zone 2 [kW]</b>	5,5

# Technical data sheet

Technical drawing



## Cooking range drop-in gas 2x burner

Model

SAP Code

00007444

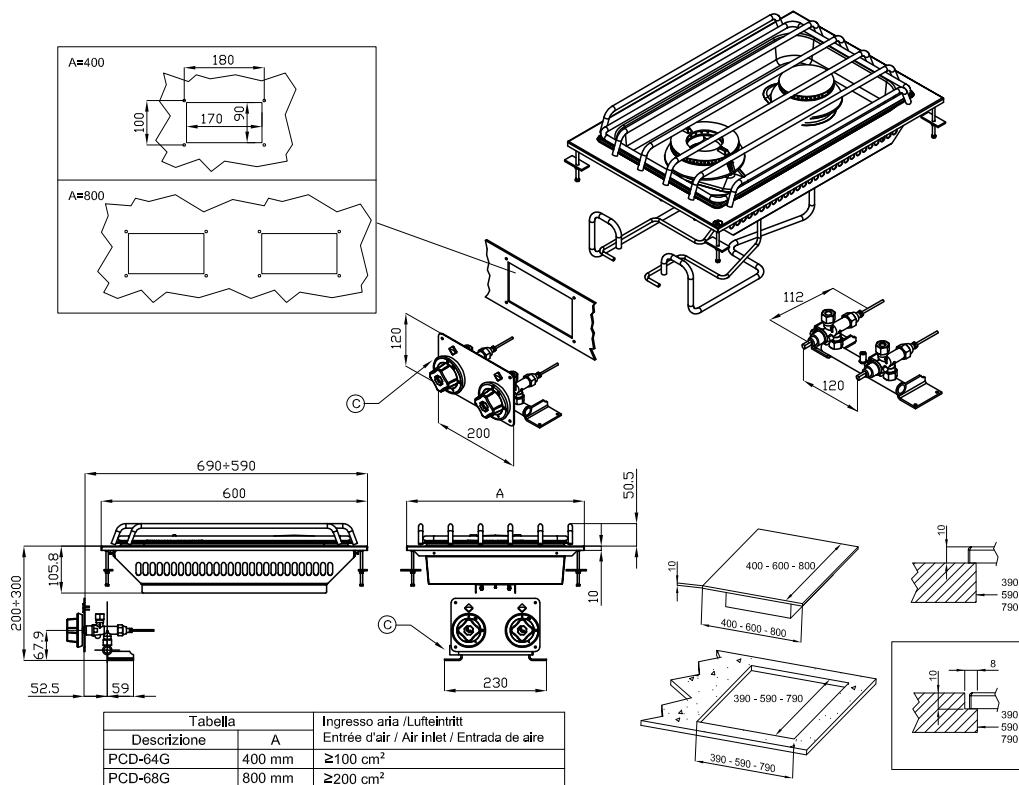

A	Data plate		C	Gas connection	ISO 7-1 1/2" M
---	------------	--	---	----------------	----------------

# Technical data sheet

## Product benefits



### Cooking range drop-in gas 2x burner

Model

SAP Code

00007444

1

#### Massive construction of burners

high performance and efficiency  
cast iron burners removable  
long life

- energy saving (perfect combustion)
- time saving for food preparation
- easy maintenance/cleaning

2

#### Degree of protection of the control elements IPX5

maintenance-free system  
resistance to splash water  
long life

- savings on service interventions
- easy cleaning and maintenance of equipment

3

#### All-stainless design

the material does not cut  
wear resistance of the material  
long life

- savings on service interventions
- easy cleaning and maintenance of equipment

4

#### Hygienic moldings of the top plate

absence of sharp corners and edges (potential places where dirt could stick)  
smooth transitions

- easy quick cleaning

5

#### Variability

the possibility of attaching to a fixed plate as part of a monoblock  
the possibility of creating one module  
long life

- cost saving
- space saving
- long service life

6

#### Safety element - thermocouple

safe service for staff  
there is no unnecessary gas leakage  
long life

- savings on service interventions
- easier and faster operation

# Technical data sheet

Technical parameters



## Cooking range drop-in gas 2x burner

Model

SAP Code

00007444

**1. SAP Code:**

00007444

**2. Net Width [mm]:**

400

**3. Net Depth [mm]:**

600

**4. Net Height [mm]:**

110

**5. Net Weight [kg]:**

16.00

**6. Gross Width [mm]:**

470

**7. Gross depth [mm]:**

700

**8. Gross Height [mm]:**

530

**9. Gross Weight [kg]:**

20.00

**10. Device type:**

Gas unit

**11. Construction type of device:**

Drop-in

**12. Power gas [kW]:**

13.000

**13. Ignition:**

Eternal flame

**14. Type of gas:**

Natural gas, propane butane

**15. Protection of controls:**

IPX5

**16. Material:**

Stainless steel

**17. Worktop material:**

AISI 304

**18. Worktop Thickness [mm]:**

2.00

**19. Number of zones:**

2

**20. Power consumption of the zone 1 [kW]:**

7,5

**21. Power consumption of the zone 2 [kW]:**

5,5

**22. Number of power control stages:**

6

**23. Service accessibility:**

From the front by removing the front panel and waste fluid containers

**24. Safety thermocouple:**

Yes

**25. Number of burners/hot plates:**

2

**26. Type of gas cooking zones:**

Cast iron burners

**27. Connection to a ball valve:**

1/2